



CAUTION

PLEASE READ THIS ESD USER HANDBOOK COMPLETELY BEFORE ASSEMBLY. THESE PRODUCTS ONLY HAVE THE ELECTROSTATIC DISSIPATING CHARACTERISTICS SPECIFIED IF PROPERLY USED AND GROUNDED.

Avoid damaging the ESD laminates and paints in any way with sharp objects. **Damaged, or irregularly maintained ESD protected work surfaces can lead to loss of ESD protection.**

Keep non-conductors and unnecessary materials away from an ESD protected environment.

Ensure that all users of the ESD working environment are aware of the necessity to observe the company's ESD control standards.

Correct assembly, operation, care, and maintenance of the ESD workstation are essential for ESD compatibility. **The customer is responsible for the ESD compatibility of all installations.**

Do not store, transport, or handle static sensitive components unless in an ESD safe environment.

Always wear a wrist strap or other personal grounding device when working at an ESD protected area.

If you are missing any of the assembly instructions listed in this guide, please visit our website at: www.listaintl.com and search for "assembly instructions".



ESD User Handbook



making workspace work®

Table of Contents

Introduction.....	2
Definition of Symbols.....	3
Definition of Terms.....	3
Specifications.....	4
Care and Use.....	4
Testing Methods.....	5
Isolation FAQ's.....	6
Cabinet Grounding.....	7
Workbench Grounding.....	8
Workbench Accessories.....	9

What is ESD?

Electrostatic Discharge (ESD) is a natural occurrence in which electricity is passed through our body, or other conductor, and discharges onto some object. For example, the shock we feel when we touch a doorknob is an ESD. This natural occurrence is becoming a very hot topic in the field of electronics assembly due to the costly damage ESDs can cause to sensitive electronic equipment.

What can a company do to prevent ESD Damage?

A priority for any company with ESD concerns should be to implement an ESD program and appoint an ESD Coordinator. **For assistance with the development of an ESD Control Program, refer to the ANSI/ESD standard s20.20.** It would be the objective of this program to reduce the potential for ESD related damage. One of the ways to do this is to carefully select and maintain the workstation. The costs associated with ESD damage far out weigh the capital investment needed to provide an ESD protected workstation.

What are the Resistivity Ranges?

Conductive: Low resistance; carries electric charge quickly.

$$< 10^5 \Omega / \text{square}$$

Dissipative: The increased resistance slows the transfer of charge from one point to another, offering increased protection during ESD events.

$$\geq 10^5 \text{ and } < 10^{12} \Omega / \text{square}$$

Insulative: High resistance; does not conduct electric charges well.

$$\geq 10^{12} \Omega / \text{square}$$

Definition of Symbols

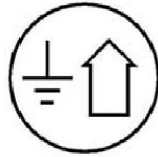
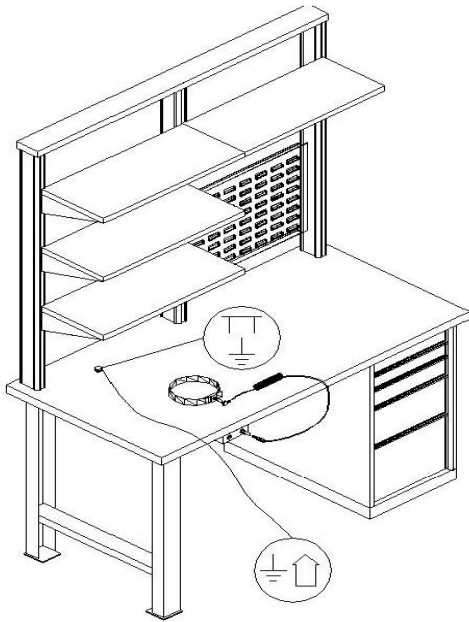

Earth Ground:

Connection to earth to establish zero potential (voltage) using ground cord part number GCT.

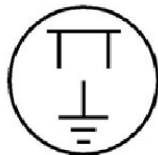

Common Ground Point:

Point on the worksurface that is connected to earth ground.

Definition of Terms

Wrist straps (WS): Provides an electrical connection between the wearer's skin and the ground. Wrist straps keep the wearer at a low electrical potential at all times. Wrist straps are one of the most important steps in ESD control, solving 75-80% of all static control problems.

Ground Cord Top (GCT): This is the main ground cord for workbench applications. This hardware connects a common ground point (Static Dissipative Top) to the earth ground. Kit includes a brass stud with hardware, and a 9 foot cord with a 1M Ω resistor.

Ground Cord Shelf (GCS): This hardware connects accessories (shelves, cabinets) to the established common ground point. Kit includes a brass stud with hardware, and a 9 foot cord without resistor.

Resistor: Located on the Ground Cord Top (GCT) and the Wrist Strap (WS), acts as a fuse between the operator and ground. **ONLY USE THE GROUND CORD WITH RESISTOR (GCT) BETWEEN THE EARTH GROUND AND THE COMMON GROUND POINT.**

Ground Loop: This occurs when there are more than one ground attached to an ESD protected workbench. The primary ground cord (GCT) has a $10^6 \Omega$ resistor in line to ground. If a ground cord (similar to the third wire on most electrical components) is used, there is no resistor, and this is an easier path to ground. This is not desired, and should be avoided.

Specifications

ESD Paint: Entirely covers workbench accessories, the cabinet housing and drawers of a cabinet if specified. The ESD painted drawers will transmit the charge through bearings and the drawer track to the grounded cabinet.

Surface Resistance: 105 - 109Ω (measured at 100V)

Static Dissipative (SD) Tops and Shelves: Contain a “carbon scrim” dissipative layer which conducts the charge away from the workbench.

Point to Point Resistance, per EOS/ESD - S4.1:

At 40-60% RH*: 106 - 107 Ω

At 20-40% RH*: 107 - 108 Ω

At 10-20% RH*: 108 - 109 Ω

Point to Ground Resistance, per EOS/ESD - S4.1

At 40-60% RH*: 106 - 107 Ω

At 20-40% RH*: 107 - 108 Ω

At 10-40% RH*: 108 - 109 Ω

Static Decay Rate: per FMTS 101C, method 4046:

At 50% RH*: 0.01 seconds

At 10% RH*: 0.02 seconds

(* **Relative Humidity**)

Conductive Plastic Insert Boxes and Slotted Grooved Trays: Conductive boxes are molded from a permanently conductive high impact polystyrene compound (PS-723), to provide protection from electrostatic discharge.

Surface Resistivity: 200 Ω/square

Care and Use

- Avoid damaging ESD laminates and paint with sharp objects. This can affect the ESD protective properties.
- All ESD protected areas require regular care and maintenance, as well as checks and inspections. **These are on going user responsibilities.**
- Damaged ESD work surfaces can lead to loss of ESD protection.
- Check all ESD installations regularly for damage, wear and tear. Failure to do so may result in loss of ESD protection.
- Check the ESD workstation’s protection characteristics frequently. See your ESD Coordinator for further information.
- Clean all surfaces periodically, using a plain cotton rag with a good ammoniated detergent. Dust and dirt may cause conditions that cause electrostatic discharge.
- Do not use cleaning materials containing wax or aggressive solvents that may modify the electrical properties of the work surface.
- Do not use brushes or other abrasive cleaning implements.

Testing Methods

Electrostatic dissipative workstation resistance properties are measured using a Megohmmeter. **ESD Association standard S4.1 recommends using a measuring apparatus capable of delivering 10 (± 1) volts and 100 (± 10) volts using two 5 pound electrodes.**

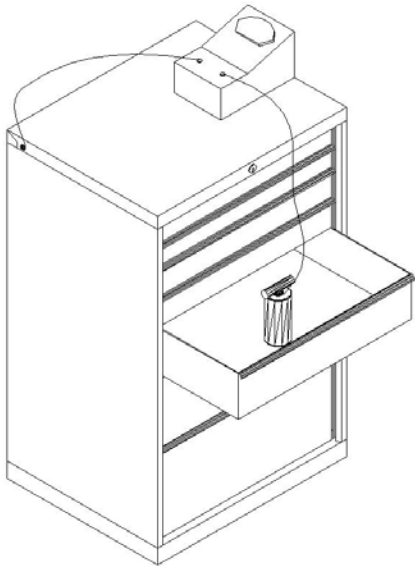

Resistance to Ground (or Groundable Point) measures the total resistance between the surface through the ground cord. According to EOS/ESD - S4.1, resistance to ground should be measured using the apparatus listed above with one electrode placed on the surface and the other terminal connected to a groundable point. The resistance should measure between 10^6 and 10^9 ohms.

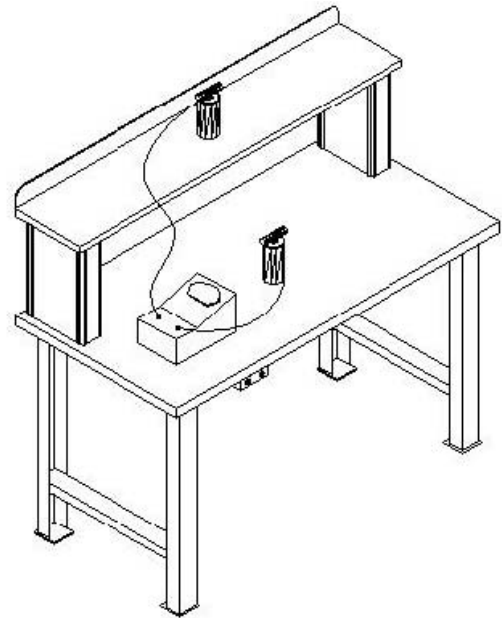

Point to Point Resistance (or Surface Resistance) is the resistance measured between two points on a static control surface. According to EOS/ESD - S4.1, using the apparatus listed above, the electrodes should be spaced ten inches apart and at least two inches from the edge of the surface. The resistance should measure $\geq 1M\Omega$. **Surface Resistivity** is a test used to measure how freely charges flow through a material (measured in Ω / square). It is generally used to measure items that are not typically grounded directly.

For additional information, or to get copies of the ESD standards or test methods, visit the ESD Association website at <http://www.esda.org>.

Isolation FAQ

If your workbench includes electrical components, you **must** isolate those components from the workbench to ensure proper grounding.

What is the benefit?

Isolation of electrical components helps ensure that the electric charge dissipated from the worksurface goes through the correct path to ground (through the ground cord with the 1 M-Ω resistor). Electrical components (with third wire ground) do not have this resistor, making it a quicker path to ground, unless this path is isolated from the charge.

How is this done?

Electrical charges look for the quickest path to ground. Since the electrical ground does not have any resistance, this path is quicker than the primary worksurface ground. Adding insulative hardware or pads between the electrical products and the product they attach to prevent this path from occurring.

How do we make sure it works?

Testing the overall bench:

Using a Megohmmeter, the workbench resistance to ground should measure at least 106 ohms. Perform this test by measuring the resistance between the brass common ground stud (which you installed on the bench) and the earth ground. If the resistance is less than 106 ohms, then there is a ground loop, and it must be isolated from the bench.

Testing individual components to ensure isolation:

Using a Megohmmeter, measure the point to point resistance between all connection points of an electrical connection (power strip, light, etc), and the electrical outlet ground wire. The resistance should be greater than 106 ohms or this will be a path to ground.



Grounding Instructions for ESD Painted Cabinets

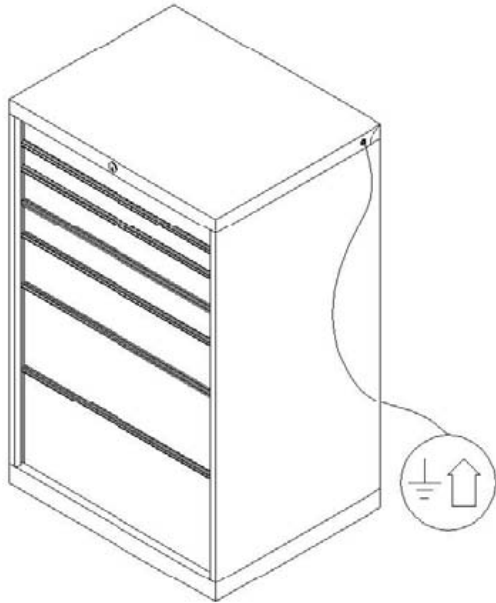

Stand Alone Cabinets

- Determine where you want to install the ground cord; this location should be installed in the top or bottom covers of the cabinet and should be at least 5 inches from the front/rear of the cabinet.
- Using a center punch, create an indentation in the cabinet housing.
- Use a drill with a #19 (.166 inch) drill bit to drill the hole into the cabinet.
- Insert the 10-24 x 1/2" self threading screw through the eye of the ground cord and screw into cabinet. The end of the ground cord closest to the inline resistor should be connected to this point. This is your common ground point.
- Drawers do not need to be grounded, as the charge is transferred through the metal components connecting the drawer to the cabinet housing. **Always test your cabinet to ensure proper grounding.**

Multiple In-line Cabinets

- Ground your first cabinet as per the stand alone cabinet instructions.
- The row of cabinets should be bolted together, if they aren't already, for proper grounding. One of the bolts should include a metal lock washer on both the nut side and the bolt side of the cabinets. This will ensure that you are getting a clean connection to the cabinet ground. **Always test your cabinet configuration to ensure proper grounding.**

Stand Alone Cabinet with Static Dissipative Counter Top

- Remove the top drawers of the cabinet. The Brass Ground Stud will be used to connect the static dissipative top to the cabinet. Determine a location for the brass ground stud, keeping in mind that the counter top is connected to the cabinet using lag screws inside the cabinet. This location should be at least 2 inches from the edge of the counter top.
- Using a drill with a 5.5mm (7/32") drill bit, drill into the static dissipative top, through the cabinet housing. **It is important to use the correct sized drill bit to ensure proper contact with the conductive "scrim" layer of the counter top.**
- Place the ground stud in hole and use a hammer to tap the "knurled" end of the stud into the top.
- Fasten the ground stud using the brass nut, with the brass washer in between, then follow the instructions for the Stand Alone Cabinets. **Always test your workstation to ensure proper grounding.**

Workbench Grounding Instructions

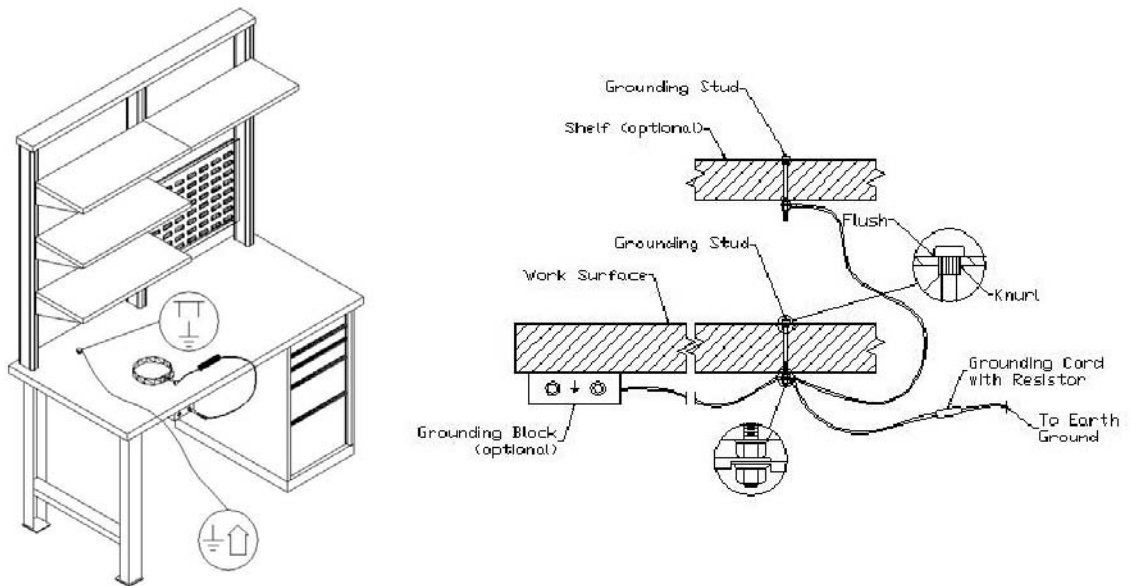

Workbenches with Static Dissipative tops

- Using a drill with a 5.5mm (7/32") drill bit, drill into the Static Dissipative top. **It is important to use the correct sized drill bit to ensure proper contact with the conductive “scrim” layer of the counter top.**
- Place the ground stud in hole and use a hammer to lightly tap the “knurled” end into the top.
- Fasten the ground stud using the brass nut, with the brass washer in between. This is your common ground point.
- Attach the primary ground cord from the common ground point to an approved grounding location. The end of the ground cord closest to the inline resistor should be connected to this point.

All electrical equipment used at an ESD workstation should be connected to Ground Fault Circuit Interrupt (GFCI) outlets.

*Note: Cabinets and other accessories may also be connected to the workbench common ground point using the cabinet grounding instructions. If you are connecting to a common ground point, you should not use a ground cord with a 1 M-Ω resistor. **ONLY USE THE GROUND CORD WITH RESISTOR (GCT) BETWEEN THE EARTH GROUND AND THE COMMON GROUND POINT.**

Once your workbench is assembled, it is important to test the overall bench grounding system to the common ground point .

Workbench Accessory Grounding Instructions

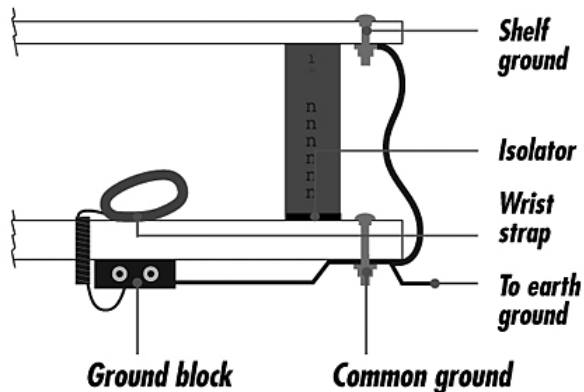

Static Dissipative Shelves

- Similar to the instructions for the Static Dissipative top, determine the location of the ground stud, drill and then tap the ground stud into your shelf.
- Using the ground cord without the resistor (GCS), connect your shelf to the common ground point. **Shelves should not be connected directly to ground.**

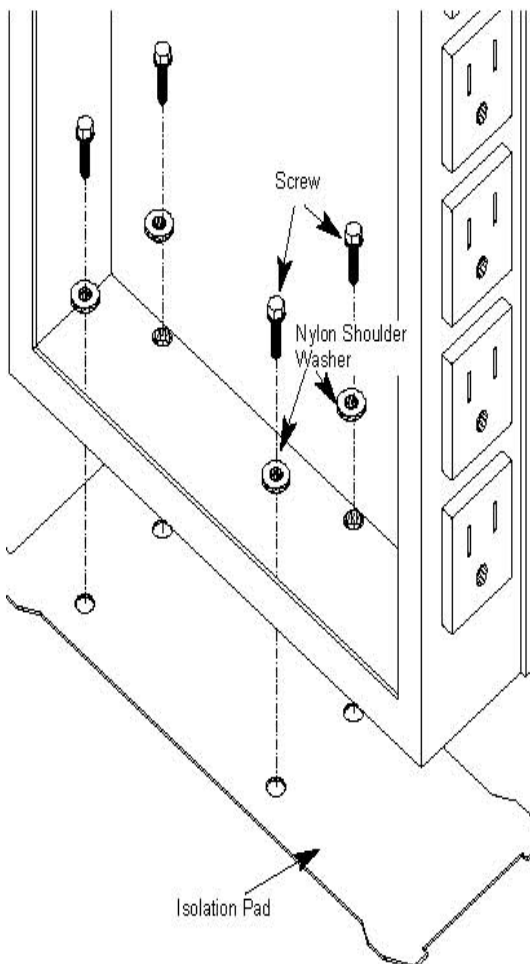

Instrument Riser Shelf Supports (IRSS)

To isolate powered instrument riser shelves, follow the instructions shown in the Workbench Assembly Instructions. Please incorporate the following steps into these instructions:

- After drilling the pilot holes and before fastening the IRSS to the bench top, place the isolation pad between the IRSS and the Static Dissipative Top, making sure the holes line up.
- Insert four $\text{Ø}1/4" \times 1/16"$ long nylon shoulder washers into the holes at the bottom of the IRSS.
- Fasten IRSS with the screws provided and finish the installation using the Workbench Assembly Instructions.

Once your bench is assembled, it is important to test the overall bench grounding system to ensure proper grounding and isolation from ground loops.

Note: Isolation is not required between the underside of the upper shelf (the core of the shelf) and the IRSS, unless there is a bull nose (radius) front or rear edge and the laminate is in contact with the IRSS.

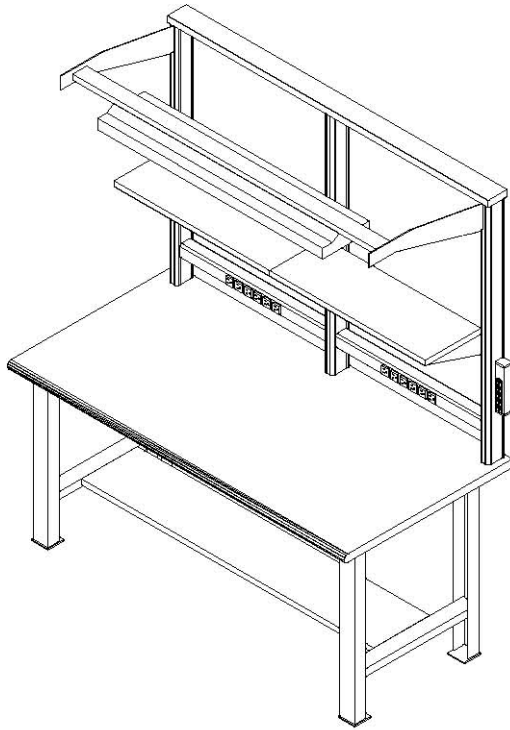

Nexus

Shelves painted with static dissipative paint, used in conjunction with static dissipative tops, are grounded using the workbench ground system (through the common ground point). When the Nexus system is screwed into the static dissipative laminate, the screw conducts the charge to the top, which carries the charge to the workbench ground point, where the charge is brought to ground through the 1 MΩ resistor.

Isolation is necessary to ensure that this charge does not go directly to ground through any of the attached electrical components. The following instructions cover the standard electrical components Lista offers in Nexus applications. Other applications, outside the scope of Lista's standard product application, will require similar consideration.

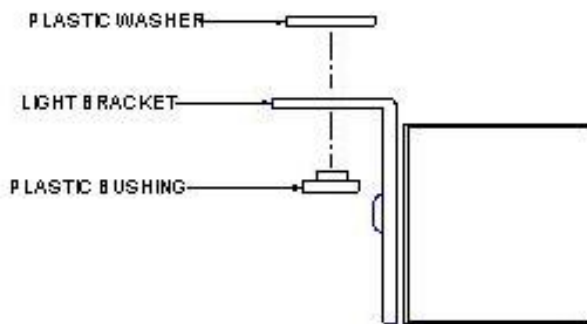

Overhead Light

Assemble the Nexus starter and adder sections according to the Nexus Accessory System - Instructions for Assembly, included with your shipment. Please incorporate the following instructions into your installation:

Insert the Plastic Bushings in the mounting holes of the Light Brackets. Sandwich the Plastic Washers between the Light Brackets and the Light Support Rail when installing the Light.

Note: Other utility lights (FLF-18, for example) should be attached using the magnetic strips provided, and not using nuts and bolts or tek-screws. The magnetic strip acts as an insulator. In some cases, the weight of the light may be more than the magnet can support. Screws may be used, but must be isolated from metal objects accordingly.

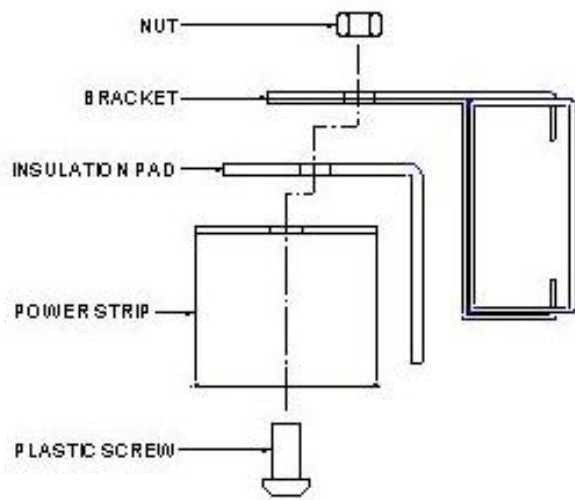

Vertical Power Strip

While following the Nexus Accessory System - Instructions for Assembly included with your shipment, please include the following steps:

Before attaching the Power Strip to the Brackets peel the paper backer off the Insulation Pad. Stick the Pad to the Bracket and assemble as shown.

Once your bench is assembled, it is important to test the overall bench grounding system to ensure proper grounding and isolation from ground loops.



Wrist Strap (WS) & Ground Block (GB)

- Choose a location under your workstation to place the Ground Block.
- Using the 2 #8 self-tapping screws, screw the Ground Block into the underside of the workbench top.
- Connect the ground block directly to the earth ground. There is a 1 Mega-ohm resistor already incorporated into the wrist strap. Connecting the ground block to the common ground point would increase the resistance to ground, causing a resistance that may be outside acceptable limits. Cable clips are included for wire management.
- Connect up to two Wrist Straps to the Ground block using the banana jacks built into the front of the Ground Block. **Always test your wrist strap/ground block to ensure proper grounding.**



Lista International Corp.
106 Lowland Street
Holliston, MA 01746-2094 USA
Customer Service: (800)722-3020
Telephone: (508) 429-1350
Fax: (508) 429-0711
E-mail: sales@listaintl.com www.listaintl.com
Document Number: MD023A3, Rev 3, 11/2007
© 2007 Lista International, all rights reserved

ISO 9001 Certified